

FREE-STANDING PORTABLE CLIMBING WALL

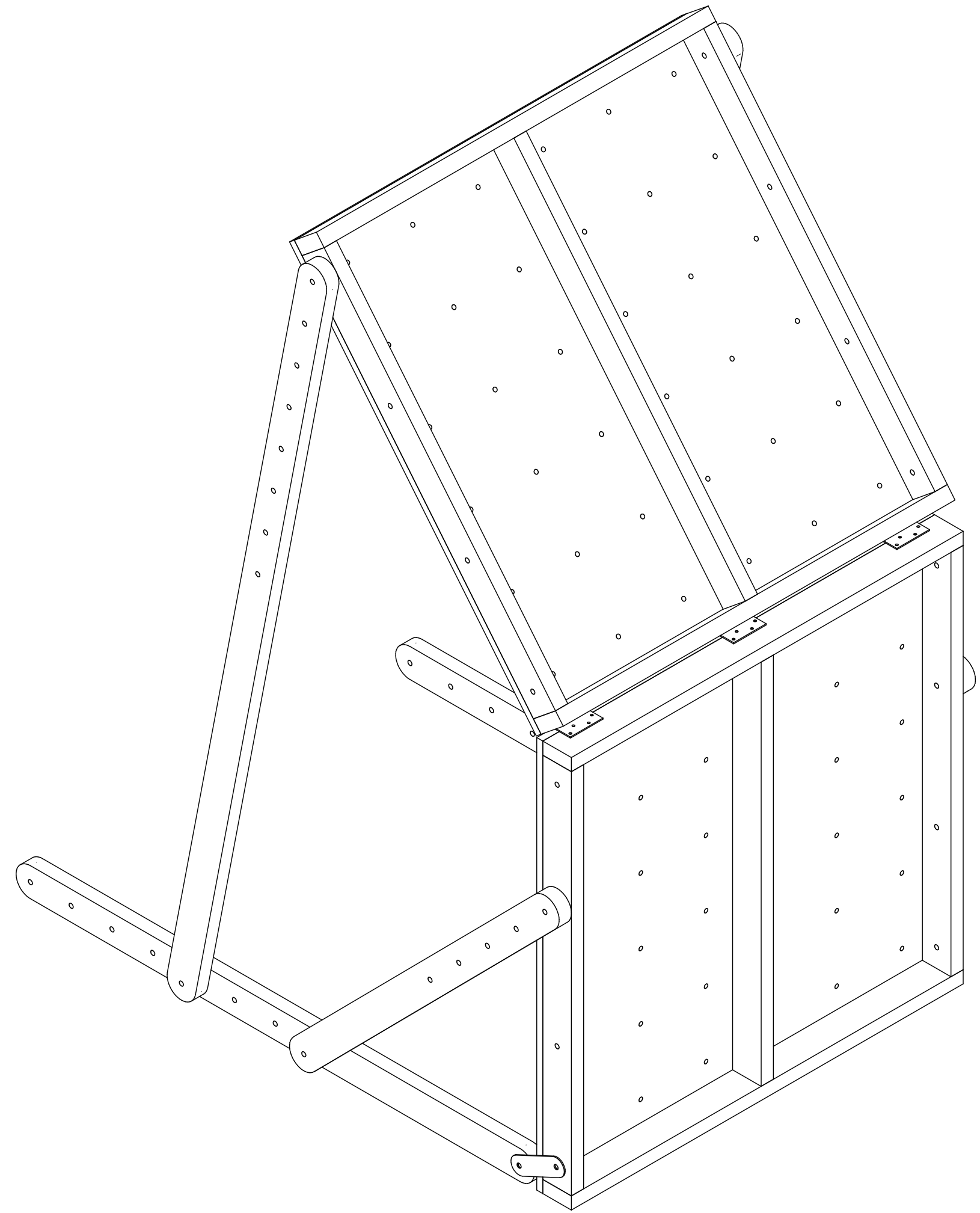

THIS DRAWING IS THE PROPERTY OF MGB ENGINEERING, LLC. THE INFORMATION CONTAINED IN THIS DRAWING IS CONFIDENTIAL AND MAY NOT BE COPIED OR USED IN WHOLE OR IN PART WITHOUT PRIOR WRITTEN PERMISSION OF MGB ENGINEERING.

MATERIAL WOOD		MGB ENGINEERING, LLC				
FINISH NONE	<small>ALL DIMENSIONS INCH</small> 0 ± 0.1 0.0 ± 0.05 0.00 ± 0.01 0.000 ± 0.005 <small>ANGLES ± 0°30'</small>	TITLE PORTABLE CLIMBING WALL	DRAWING NO. XXXXXX	SHEET 1 OF 4	SCALE 1:10	REV 0

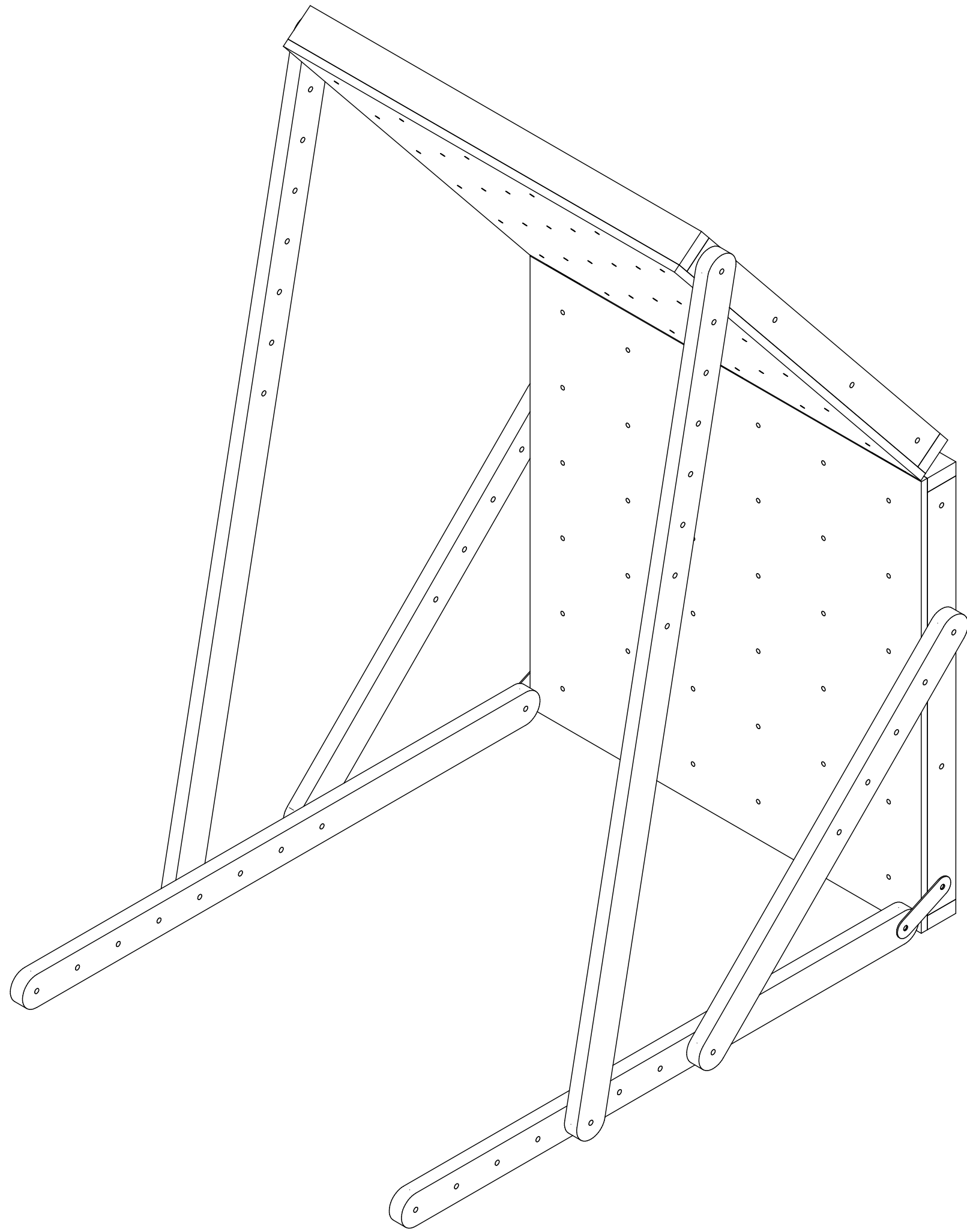
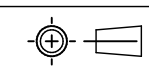
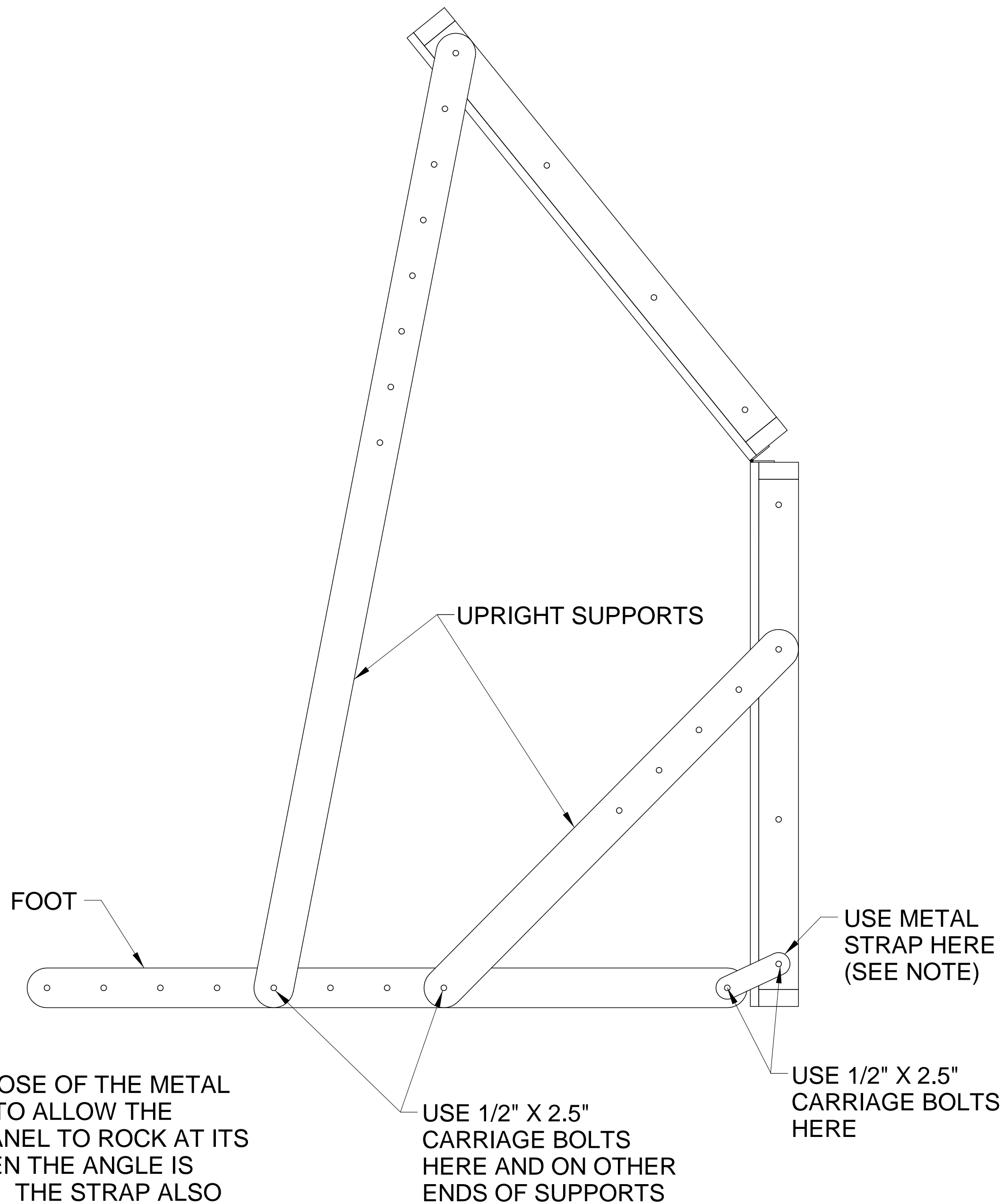

NOTE:
 THE PURPOSE OF THE METAL STRAP IS TO ALLOW THE LOWER PANEL TO ROCK AT ITS BASE WHEN THE ANGLE IS CHANGED. THE STRAP ALSO KEEPS THE FOOT ALIGNED TO THE INSIDE FACE OF THE UPRIGHT SUPPORTS.

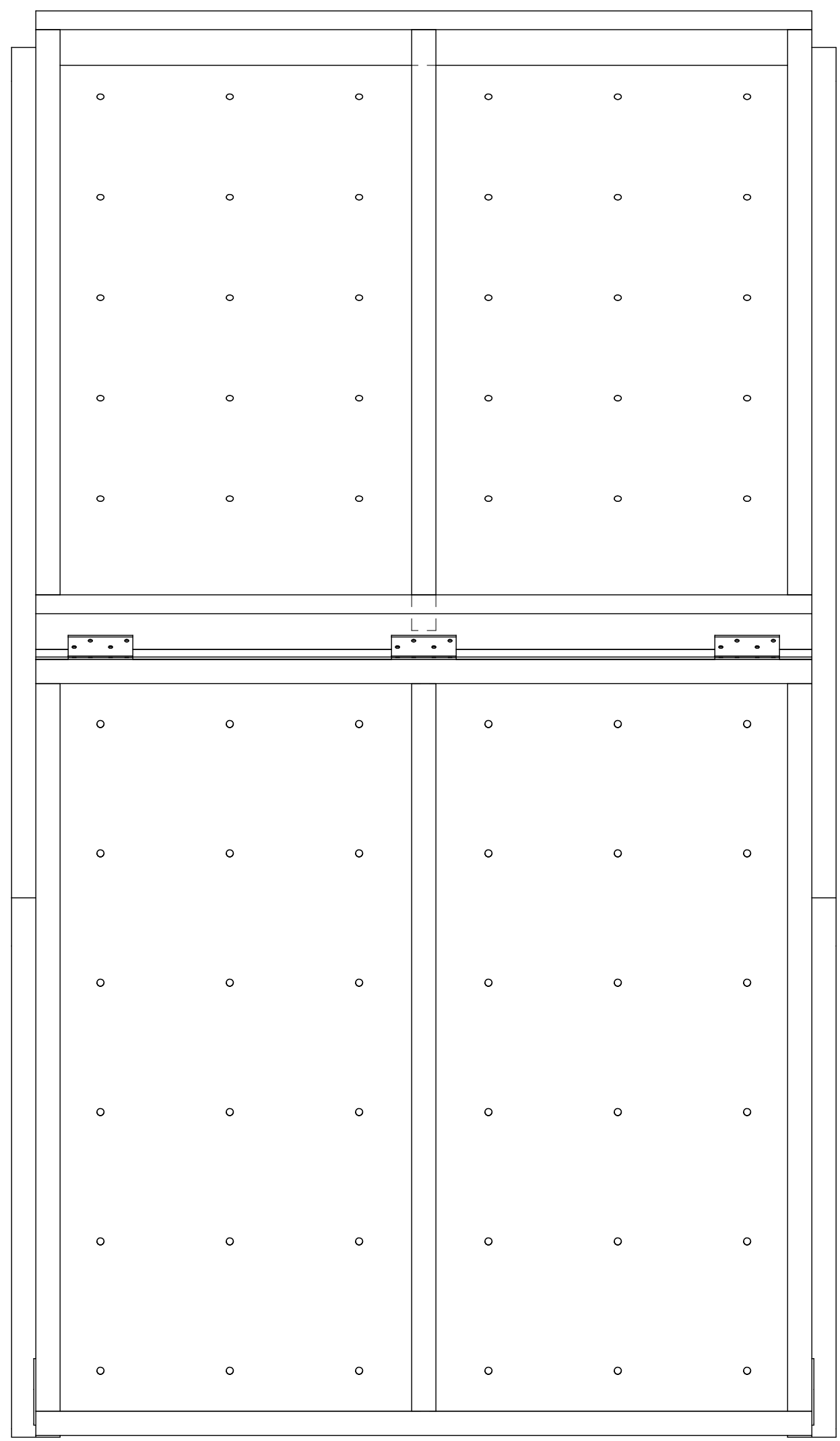

THIS DRAWING IS THE PROPERTY OF MGB ENGINEERING, LLC. THE INFORMATION CONTAINED IN THIS DRAWING IS CONFIDENTIAL AND MAY NOT BE COPIED OR USED IN WHOLE OR IN PART WITHOUT PRIOR WRITTEN PERMISSION OF MGB ENGINEERING.

MATERIAL WOOD		MGB ENGINEERING, LLC				
FINISH NONE	<small>ALL DIMENSIONS INCH</small> 0 ± 0.1 0.0 ± 0.05 0.00 ± 0.01 0.000 ± 0.005 <small>ANGLES ± 0°30'</small>	TITLE PORTABLE CLIMBING WALL	DRAWING NO. XXXXXX	SHEET 2 OF 4	SCALE 1:8	REV 0

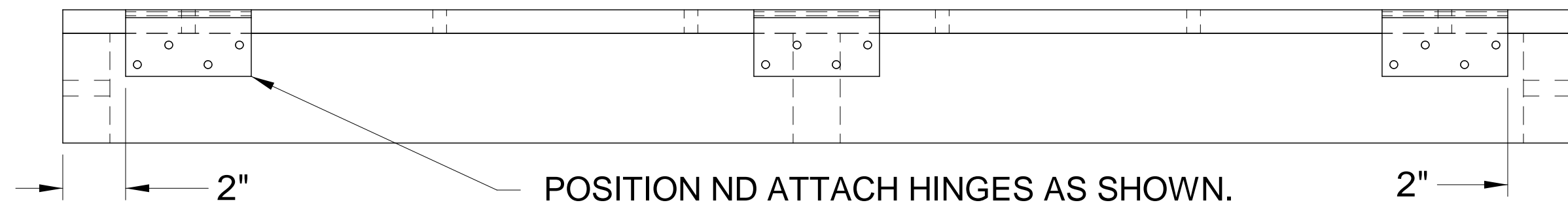

USE 2" DRYWALL SCREWS TO ATTACH PLYWOOD TO FRAME. SPACE EVERY 5-6" BETWEEN SCREWS.

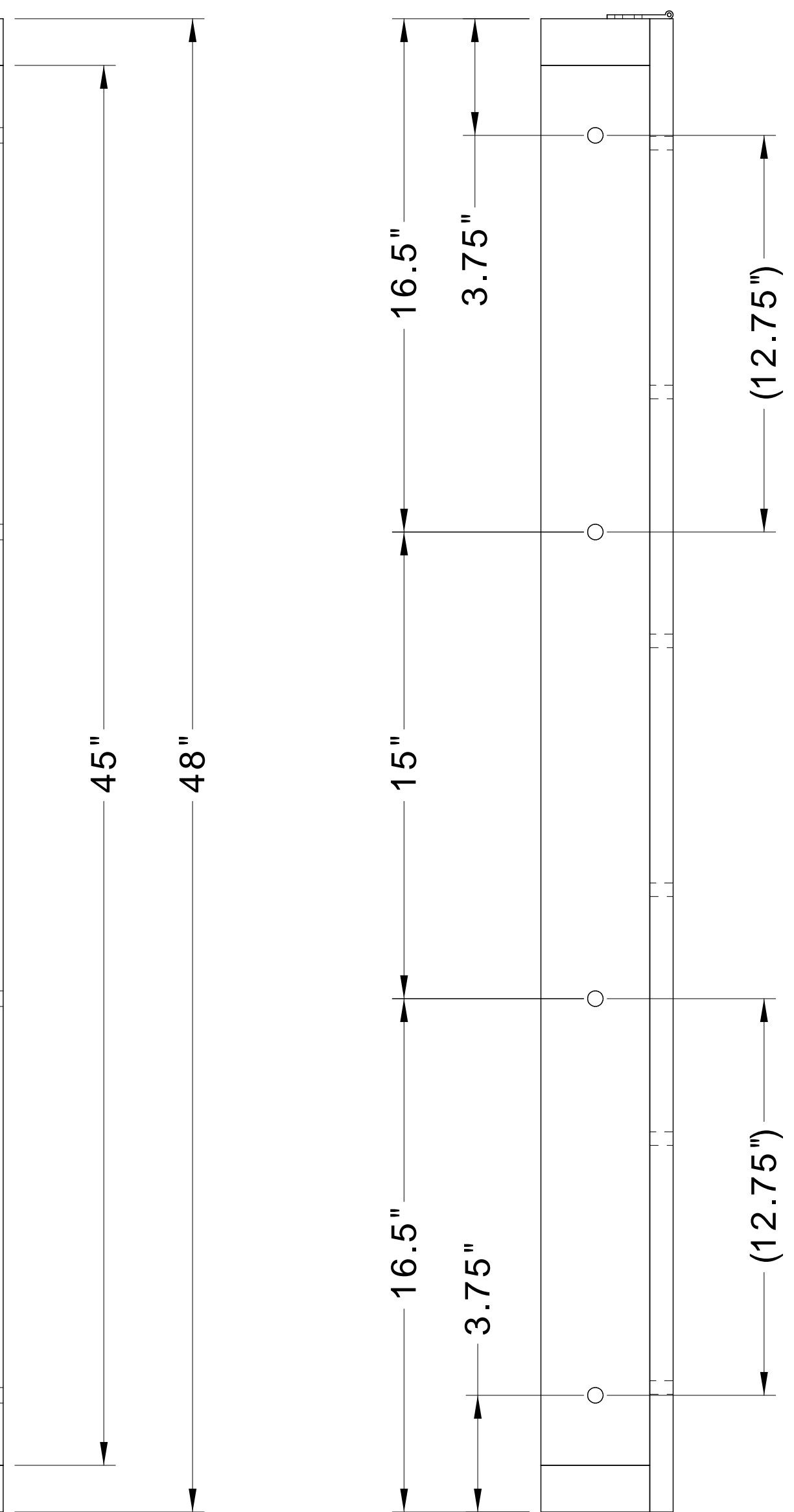
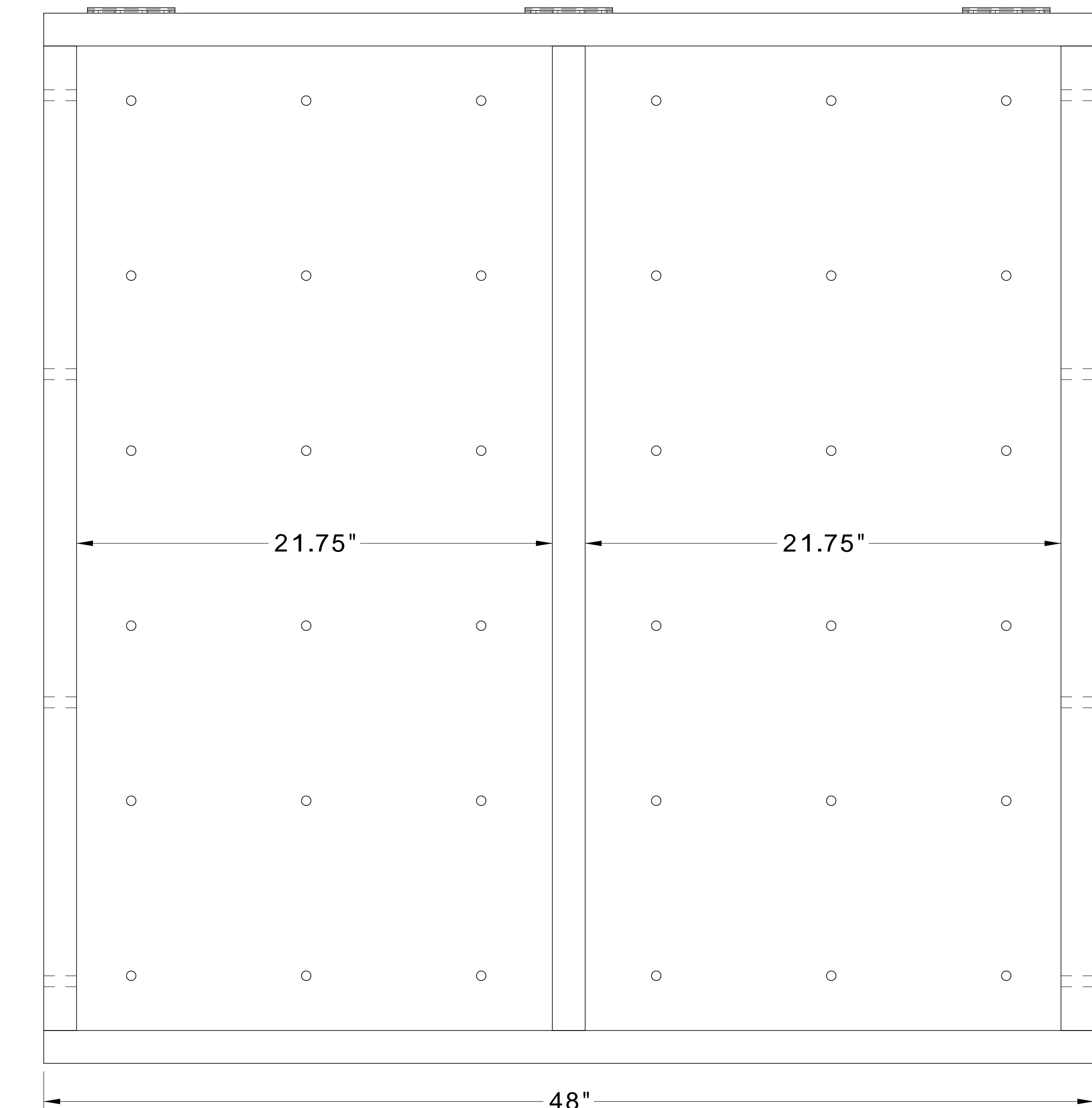

BUILD FRAME AS SHOWN USING 3" DRYWALL SCREWS TO ATTACH STUDS TOGETHER.

THIS DRAWING IS THE PROPERTY OF MGB ENGINEERING, LLC. THE INFORMATION CONTAINED IN THIS DRAWING IS CONFIDENTIAL AND MAY NOT BE COPIED OR USED IN WHOLE OR IN PART WITHOUT PRIOR WRITTEN PERMISSION OF MGB ENGINEERING.

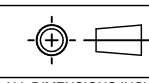
MATERIAL WOOD	 <small>ALL DIMENSIONS INCH</small> 0 ± 0.1 0.0 ± 0.05 0.00 ± 0.01 0.000 ± 0.005 <small>ANGLES ± 0°30'</small>	MGB ENGINEERING, LLC <small>TITLE</small> PORTABLE CLIMBING WALL		
FINISH NONE		<small>DRAWING NO.</small> XXXXXX	<small>SHEET</small> 3 OF 4	<small>SCALE</small> 1:4

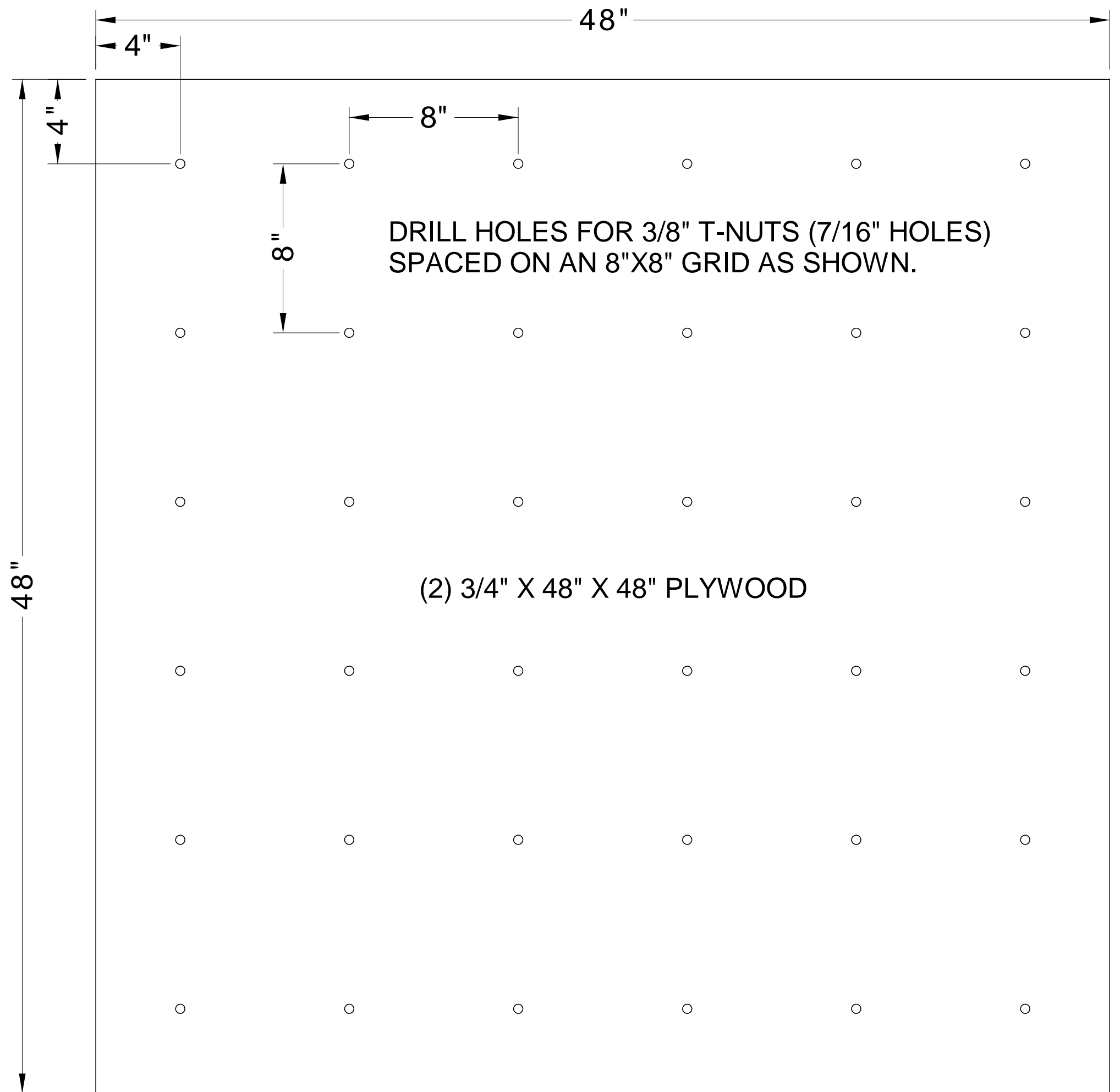
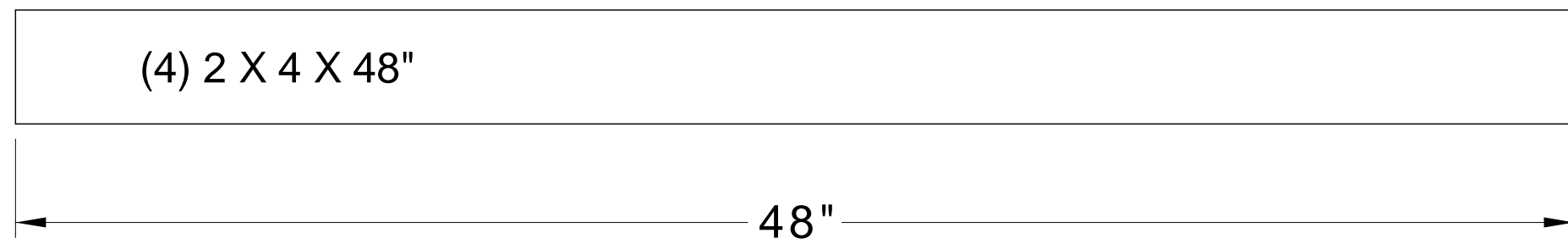
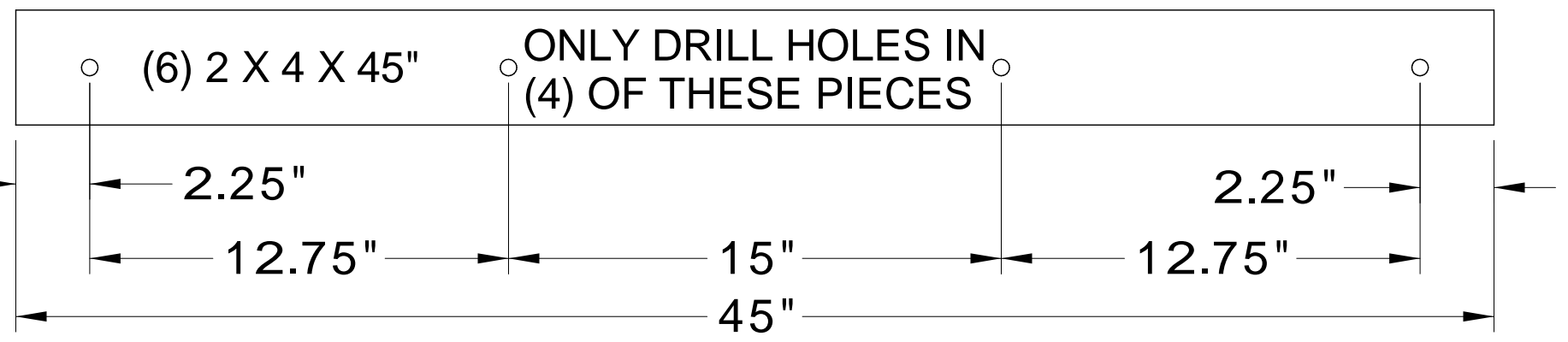
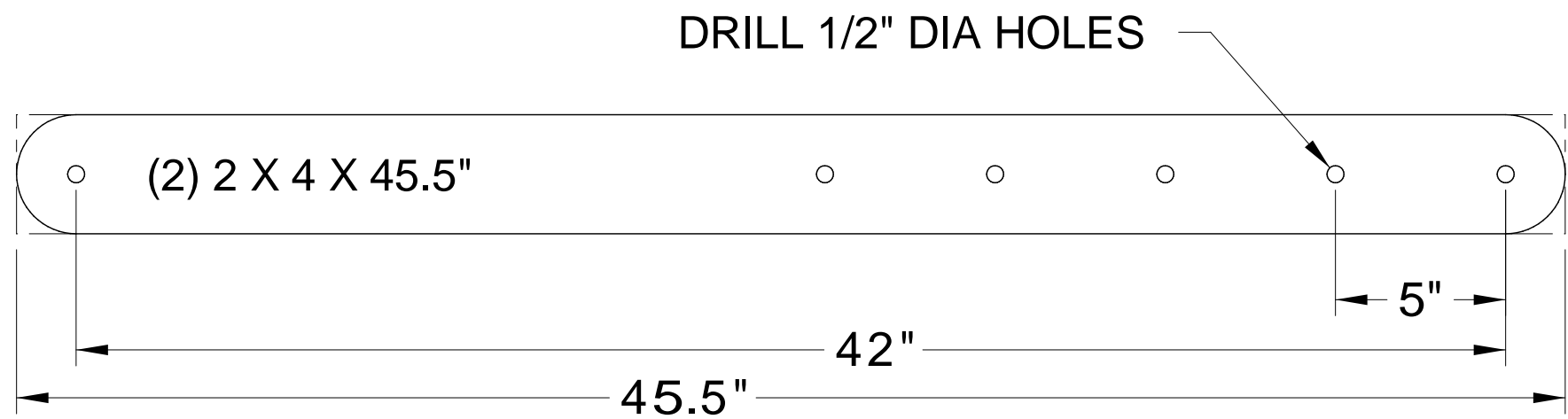
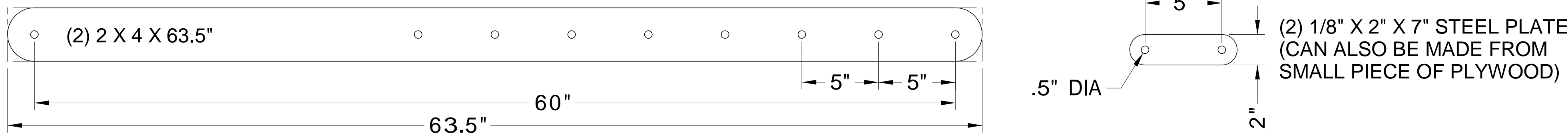
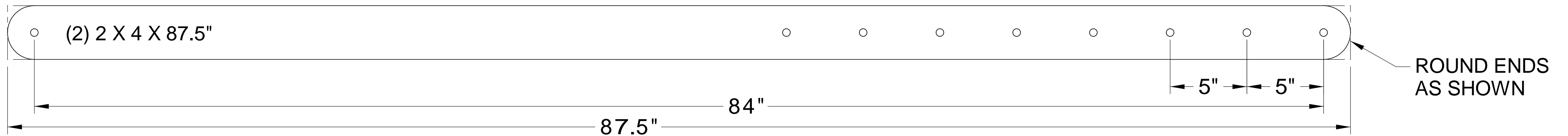

BILL OF MATERIALS:

- (2) 3/4" X 48" X 48" PLYWOOD (CUT FROM SHEET OF 5-PLY)
- (2) 2 X 4 X 87.5"
- (2) 2 X 4 X 63.5"
- (2) 2 X 4 X 45.5"
- (6) 2 X 4 X 45" ((ONLY DRILL HOLES IN 4 OF THESE))
- (4) 2 X 4 X 48"
- (2) 1/8 X 2" X 7" STEEL PLATE
- (3) 4" X 4" STEEL DOOR HINGES
- (8) 1/2" DIA X 4" LONG CARRIAGE BOLTS (WITH HEX NUTS AND WASHERS)
- (4) 1/2" DIA X 2.5" LONG CARRIAGE BOLTS (WITH HEX NUTS AND WASHERS)
- BOX OF 2" DRY WALL SCREWS
- BOX OF 3" DRY WALL SCREWS

THIS DRAWING IS THE PROPERTY OF MGB ENGINEERING, LLC. THE INFORMATION CONTAINED IN THIS DRAWING IS CONFIDENTIAL AND MAY NOT BE COPIED OR USED IN WHOLE OR IN PART WITHOUT PRIOR WRITTEN PERMISSION OF MGB ENGINEERING.

MATERIAL WOOD		MGB ENGINEERING, LLC		
FINISH NONE	ALL DIMENSIONS INCH 0 +/- 0.1 0.0 +/- 0.05 0.00 +/- 0.01 0.000 +/- 0.005 ANGLES +/- 0°30'	TITLE PORTABLE CLIMBING WALL	DRAWING NO. XXXXXX	SHEET 4 OF 4
		SCALE 1:5	REV 0	

This document was created with Win2PDF available at <http://www.daneprairie.com>.
The unregistered version of Win2PDF is for evaluation or non-commercial use only.